



PRODUCT CODE:

M-SWHUR

This wall hung urinal is perfect for temporary applications such as site sheds or mobile ablution amenities.

FEATURES & BENEFITS:

- Constructed from 304 grade 1.2mm stainless steel
- Outlet position as required for custom made
- Length as required
- 3 star WELS approved
- Rear or top inlet available for custom made
- 600mm, 900mm, 1200mm, 1500mm, 1800mm, 2400mm available off the shelf. All centre outlets. All with one top centre inlet (2400mm has two top inlets which are 600mm in from ends)

Custom made products incur a lead time



Top

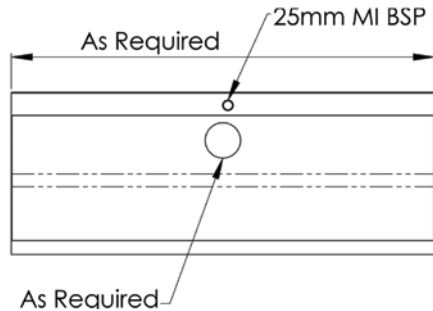

Side

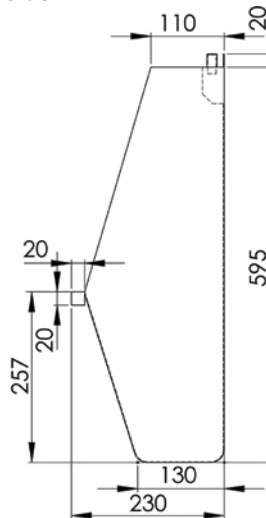
Optional Top Inlet
Accessories Kit
M-WHURACCKIT

Includes pull chain
cistern, sparge
adaptor, flush pipe,
nut and washer and
domed grate



**Suggested mounting
height from floor level
to front rim:**

Adults - 610mm

Children - 510mm



STAINLESS STEEL EVOLUTIONS
Innovate · Create · Deliver

Details accurate at time of print. Whilst all care has been taken in compiling this information, designs & dimensions shown are indicative only and should not be relied upon without prior approval.